

# L FRA Developed Option: Train Schedules

A set of preliminary train schedules was developed for the FRA Developed Option. All schedules include 5% slack time over and above the minimum running time, reflecting an allowance for minor operational variances and schedule recovery on a dedicated track system.

A highly connected route structure was developed that offers direct train service options in all major travel markets. This resulted in the development of nine different schedule pairings whose timings had to be coordinated across the network. Trains from the south headed up the I-70 mountain corridor do not go to downtown Denver, but rather turn directly west at the I-25/US-6 junction. From this junction through downtown Denver north to 96th Avenue, Fort Collins trains share the alignment with the DIA Airport service. By coordinating the times at the junction based on the use of predefined time slots, conflict-free schedules could be developed for the whole system reflecting the target train frequencies established for each route in the Spider Web diagram.

Train frequencies, times and stopping patterns are preliminary and subject to further refinement and optimization in future study phases. In addition current branch line schedules are all oriented for service to downtown Denver; they do not accommodate "backwards" flows such as from Black Hawk to Breckenridge, or from Breckenridge to Eagle Airport without a transfer. Additional schedule pairings for providing direct train service in such markets, for adding additional local stops along the corridors, developing Express/Local train services, further improving the match of train timings to individual market demands, and for minimizing equipment turn times at route termini to optimize equipment utilization, may all be developed as refinements in future study phases.

A highly peaked travel pattern is characteristic of "day trippers" but not "destination" or multi-day travelers, whose demand tends to be spread out more evenly across the day. The rail service is designed to accommodate both kinds of travel, but equipment utilization and operating efficiency considerations suggest that a system geared primarily to serving peak weekend demands of day trippers - would suffer poor equipment utilization and very high unit costs. Accordingly, an "all day" service is proposed based on fairly uniform service throughout the entire day with some capacity added in peak hours, that will give riders a lot of flexibility to travel at anytime they want to, rather than only at peak hours.

In the following train schedules, the gray highlighted areas show the various arrival departure times, with the train number (indicating the route to which the train is associated) at the top of each schedule. Some trains appear on more than one schedule, for example, train #500 starts at Colorado Springs at 5:36am and arrives at the I-25/US-6 Junction at 6:26am (see the Pueblo to Fort Collins

schedule in L.5). The train continues west on the I-70 corridor arriving Breckenridge at 7:55am (see the DIA to Eagle Airport schedule in L.2). The yellow highlighted entry at the junction point shows that it is a linked schedule; where the train switches from one segment to the next, continuing to its final destination on another page of the schedule book. The yellow times at the junction along with the train numbers can be used, if desired to match the two segments of the train schedule together for those trains that switch between the I-70 and I-25 corridors.

On I-25 south of Colorado Springs, demand drops off. To better match capacity to demand and avoid running empty trains south of Colorado Springs, some trains are proposed to turn back there. To minimize the need for transfers, two short-distance routes to Black Hawk and Breckenridge would be turned at Colorado Springs, while longer distance routes to Eagle, Fort Collins and DIA would run through to Pueblo. The Colorado Springs-Black Hawk train would serve the southern suburbs of Denver, and provide a competitive option for Colorado Springs residents as well.

### L.1 Spiderweb Train Schedule Diagram

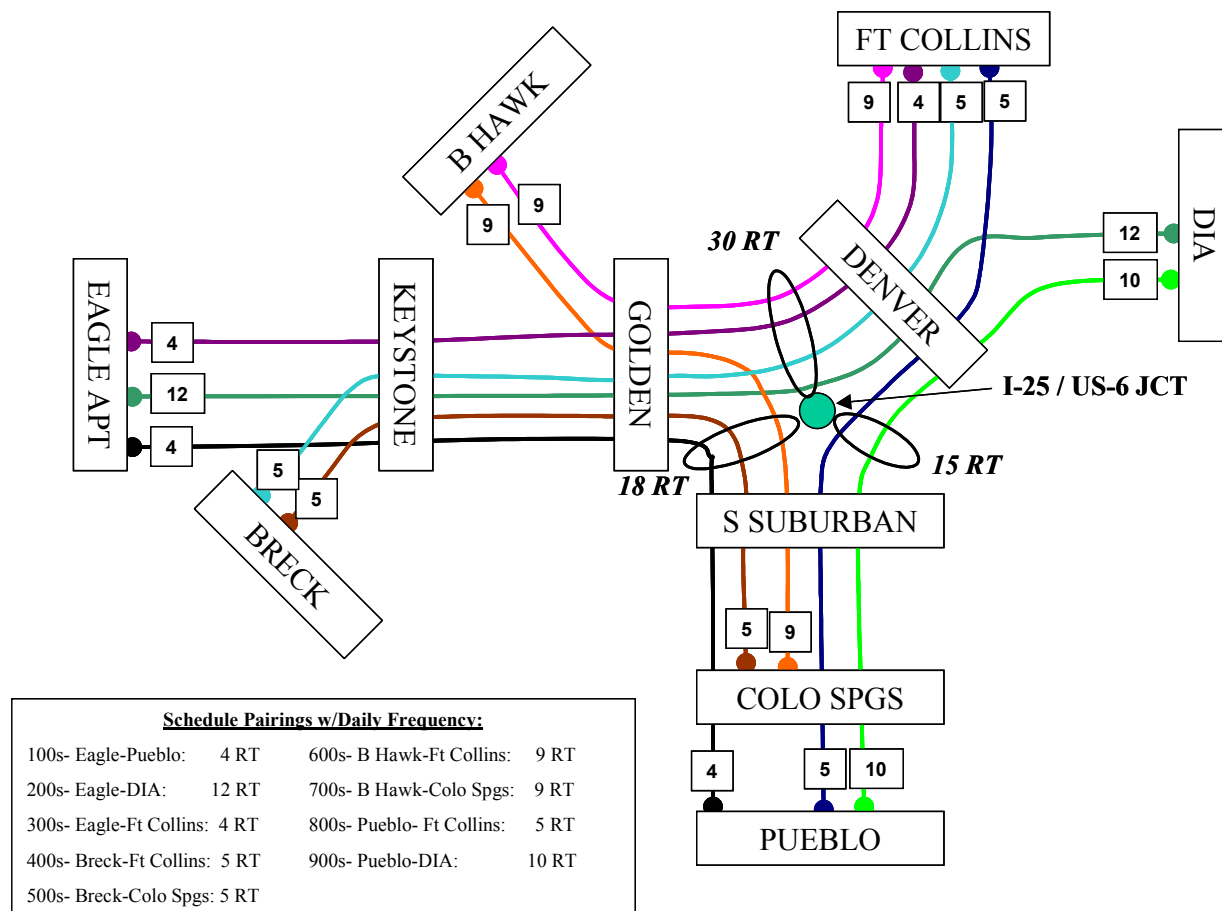

## L.2 DIA to Eagle Airport Train Schedule

Train Number	300	100	400	500	600	700	402	502	302	602	702	102	604	200	704	202	606
	(hh:mm)	(hh:mm)	(hh:mm)	(hh:mm)	(hh:mm)	(hh:mm)	(hh:mm)	(hh:mm)	(hh:mm)	(hh:mm)	(hh:mm)	(hh:mm)	(hh:mm)	(hh:mm)	(hh:mm)	(hh:mm)	(hh:mm)
DIA														9:32		10:17	
Denver - Union Station	5:59		6:14		6:29		7:44		7:59	8:29			9:29	9:44		10:29	10:44
<i>US-6 JUNCTION</i>	6:04	6:11	6:19	6:26	6:34	7:41	7:49	7:56	8:04	8:34	8:41	8:56	9:34	9:49	10:11	10:34	10:49
Suburban West	6:10	6:17	6:25	6:32	6:40	7:47	7:55	8:02	8:10	8:40	8:47	9:02	9:40	9:55	10:17	10:40	10:55
El Rancho	6:23	6:30	6:38	6:45	6:53	8:00	8:08	8:15	8:23	8:53	9:00	9:15	9:53	10:08	10:30	10:53	11:08
Black Hawk					7:31	8:38				9:31	9:38		10:31		11:08		11:46
Idaho Springs	6:37	6:44	6:52	6:59			8:22	8:29	8:37			9:29		10:22		11:07	
Loveland Pass	6:57	7:04	7:12	7:19			8:42	8:49	8:57			9:49		10:42		11:27	
Keystone	7:07	7:14	7:22	7:29			8:52	8:59	9:07			9:59		10:52		11:37	
Breckenridge			7:48	7:55			9:18	9:25									
Copper Mountain	7:25	7:32							9:25			10:17		11:10		11:55	
Vail Station	7:59	8:06							9:59			10:51		11:44		12:29	
Avon	8:07	8:14							10:07			10:59		11:52		12:37	
Eagle Airport	8:30	8:37							10:30			11:22		12:15		13:00	

Train Number	706	204	608	708	206	610	710	504	208	404	612	712	210	304	614	714	212
	(hh:mm)	(hh:mm)	(hh:mm)	(hh:mm)	(hh:mm)	(hh:mm)	(hh:mm)	(hh:mm)	(hh:mm)	(hh:mm)	(hh:mm)	(hh:mm)	(hh:mm)	(hh:mm)	(hh:mm)	(hh:mm)	(hh:mm)
DIA		11:17			12:17				13:17				14:17				15:17
Denver - Union Station		11:29	11:44		12:29	12:59			13:29	13:44	13:59		14:29	14:44	14:59		15:29
<i>US-6 JUNCTION</i>	11:11	11:34	11:49	12:11	12:34	13:04	13:11	13:26	13:34	13:49	14:04	14:26	14:34	14:49	15:04	15:26	15:34
Suburban West	11:17	11:40	11:55	12:17	12:40	13:10	13:17	13:32	13:40	13:55	14:10	14:32	14:40	14:55	15:10	15:32	15:40
El Rancho	11:30	11:53	12:08	12:30	12:53	13:23	13:30	13:45	13:53	14:08	14:23	14:45	14:53	15:08	15:23	15:45	15:53
Black Hawk	12:08		12:46	13:08		14:01	14:08				15:01	15:23			16:01	16:23	
Idaho Springs		12:07			13:07			13:59	14:07	14:22			15:07	15:22			16:07
Loveland Pass		12:27			13:27			14:19	14:27	14:42			15:27	15:42			16:27
Keystone		12:37			13:37			14:29	14:37	14:52			15:37	15:52			16:37
Breckenridge								14:55		15:18							
Copper Mountain		12:55			13:55				14:55				15:55	16:10			16:55
Vail Station		13:29			14:29				15:29				16:29	16:44			17:29
Avon		13:37			14:37				15:37				16:37	16:52			17:37
Eagle Airport		14:00			15:00				16:00				17:00	17:15			18:00

Train Number	104	214	616	406	716	216	306	506	218	408	220	106	508	222
	(hh:mm)	(hh:mm)	(hh:mm)	(hh:mm)	(hh:mm)	(hh:mm)	(hh:mm)	(hh:mm)	(hh:mm)	(hh:mm)	(hh:mm)	(hh:mm)	(hh:mm)	(hh:mm)
DIA		16:17				17:17			18:17		19:17			20:17
Denver - Union Station		16:29	16:44	17:14		17:29	18:14		18:29	19:14	19:29			20:29
<i>US-6 JUNCTION</i>	16:26	16:34	16:49	17:19	17:26	17:34	18:19	18:26	18:34	19:19	19:34	19:56	20:26	20:34
Suburban West	16:32	16:40	16:55	17:25	17:32	17:40	18:25	18:32	18:40	19:25	19:40	20:02	20:32	20:40
El Rancho	16:45	16:53	17:08	17:38	17:45	17:53	18:38	18:45	18:53	19:38	19:53	20:15	20:45	20:53
Black Hawk			17:46		18:23						20:31			
Idaho Springs	16:59	17:07		17:52		18:07	18:52	18:59	19:07	19:52	20:07	20:29	20:59	21:07
Loveland Pass	17:19	17:27		18:12		18:27	19:12	19:19	19:27	20:12	20:27	20:49	21:19	21:27
Keystone	17:29	17:37		18:22		18:37	19:22	19:29	19:37	20:22	20:37	20:59	21:29	21:37
Breckenridge				18:48				19:55		20:48	21:03		21:55	
Copper Mountain	17:47	17:55				18:55	19:40		19:55		20:55	21:17		21:55
Vail Station	18:21	18:29				19:29	20:14		20:29		21:29	21:51		22:29
Avon	18:29	18:37				19:37	20:22		20:37		21:37	21:59		22:37
Eagle Airport	18:52	19:00				20:00	20:45		21:00		22:00	22:22		23:00

### L.3 Eagle Airport to DIA

Train Number	601	701	703	401	301	201	705	403	203	707	501	205	709	303	503	207	101
	(hh:mm)	(hh:mm)	(hh:mm)	(hh:mm)	(hh:mm)	(hh:mm)	(hh:mm)	(hh:mm)	(hh:mm)	(hh:mm)	(hh:mm)	(hh:mm)	(hh:mm)	(hh:mm)	(hh:mm)	(hh:mm)	(hh:mm)
Eagle Airport					6:10	6:25			7:10			8:10		8:55		9:10	9:18
Avon					6:33	6:48			7:33			8:33		9:18		9:33	9:41
Vail Station					6:41	6:56			7:41			8:41		9:26		9:41	9:49
Copper Mountain					7:15	7:30			8:15			9:15		10:00		10:15	10:23
Breckenridge				7:18				8:18			9:26				10:26		
Keystone				7:44	7:59	8:14		8:44	8:59		9:52	9:59		10:44	10:52	10:59	11:07
Loveland Pass				7:54	8:09	8:24		8:54	9:09		10:02	10:09		10:54	11:02	11:09	11:17
Idaho Springs				8:14	8:29	8:44		9:14	9:29		10:22	10:29		11:14	11:22	11:29	11:37
Black Hawk	6:13	6:36	8:06				9:06			10:06			11:06				
El Rancho	6:51	7:14	8:44	9:06	9:21	9:36	9:44	10:06	10:21	10:44	11:14	11:21	11:44	12:06	12:14	12:21	12:29
Suburban West	7:04	7:27	8:57	9:19	9:34	9:49	9:57	10:19	10:34	10:57	11:27	11:34	11:57	12:19	12:27	12:34	12:42
<i>US-6 JUNCTION</i>	7:11	7:34	9:04	9:26	9:41	9:56	10:04	10:26	10:41	11:04	11:34	11:41	12:04	12:26	12:34	12:41	12:49
Denver - Union Station	7:15			9:30	9:45	10:00		10:30	10:45			11:45		12:30		12:45	
DIA						10:12			10:57			11:57				12:57	
Train Number	209	405	211	603	213	711	505	305	103	215	713	605	217	607	219	715	507
	(hh:mm)	(hh:mm)	(hh:mm)	(hh:mm)	(hh:mm)	(hh:mm)	(hh:mm)	(hh:mm)	(hh:mm)	(hh:mm)	(hh:mm)	(hh:mm)	(hh:mm)	(hh:mm)	(hh:mm)	(hh:mm)	(hh:mm)
Eagle Airport	10:10		11:10		12:10			12:40	12:48	13:10			14:10		15:10		
Avon	10:33		11:33		12:33			13:03	13:11	13:33			14:33		15:33		
Vail Station	10:41		11:41		12:41			13:11	13:19	13:41			14:41		15:41		
Copper Mountain	11:15		12:15		13:15			13:45	13:53	14:15			15:15		16:15		
Breckenridge		12:03					13:56										16:56
Keystone	11:59	12:29	12:59		13:59		14:22	14:29	14:37	14:59			15:59		16:59		17:22
Loveland Pass	12:09	12:39	13:09		14:09		14:32	14:39	14:47	15:09			16:09		17:09		17:32
Idaho Springs	12:29	12:59	13:29		14:29		14:52	14:59	15:07	15:29			16:29		17:29		17:52
Black Hawk				14:13		14:51					16:06	16:13		17:13		17:51	
El Rancho	13:21	13:51	14:21	14:51	15:21	15:29	15:44	15:51	15:59	16:21	16:44	16:51	17:21	17:51	18:21	18:29	18:44
Suburban West	13:34	14:04	14:34	15:04	15:34	15:42	15:57	16:04	16:12	16:34	16:57	17:04	17:34	18:04	18:34	18:42	18:57
<i>US-6 JUNCTION</i>	13:41	14:11	14:41	15:11	15:41	15:49	16:04	16:11	16:19	16:41	17:04	17:11	17:41	18:11	18:41	18:49	19:04
Denver - Union Station	13:45	14:15	14:45	15:15	15:45			16:15		16:45		17:15	17:45	18:15	18:45		
DIA	13:57		14:57		15:57					16:57			17:57		18:57		

Train Number	407	221	105	609	223	307	409	509	611	107	613	717	615	617
	(hh:mm)	(hh:mm)	(hh:mm)	(hh:mm)	(hh:mm)	(hh:mm)	(hh:mm)	(hh:mm)	(hh:mm)	(hh:mm)	(hh:mm)	(hh:mm)	(hh:mm)	(hh:mm)
Eagle Airport		16:10	16:33		17:10	17:25				18:03				
Avon		16:33	16:56		17:33	17:48				18:26				
Vail Station		16:41	17:04		17:41	17:56				18:34				
Copper Mountain		17:15	17:38		18:15	18:30				19:08				
Breckenridge	17:18						19:03	19:11						
Keystone	17:44	17:59	18:22		18:59	19:14	19:29	19:37		19:52				
Loveland Pass	17:54	18:09	18:32		19:09	19:24	19:39	19:47		20:02				
Idaho Springs	18:14	18:29	18:52		19:29	19:44	19:59	20:07		20:22				
Black Hawk				19:13					20:28		20:43	20:51	20:58	21:13
El Rancho	19:06	19:21	19:44	19:51	20:21	20:36	20:51	20:59	21:06	21:14	21:21	21:29	21:36	21:51
Suburban West	19:19	19:34	19:57	20:04	20:34	20:49	21:04	21:12	21:19	21:27	21:34	21:42	21:49	22:04
US-6 JUNCTION	19:26	19:41	20:04	20:11	20:41	20:56	21:11	21:19	21:26	21:34	21:41	21:49	21:56	22:11
Denver - Union Station	19:30	19:45		20:15	20:45	21:00	21:15		21:30		21:45		22:00	22:15
DIA		19:57			20:57									

### L.4 Fort Collins to Pueblo

Train Number	300	400	600	800	701	802	402	302	602	804	703	604	900	705	606	902	707
	(hh:mm)	(hh:mm)	(hh:mm)	(hh:mm)	(hh:mm)	(hh:mm)	(hh:mm)	(hh:mm)	(hh:mm)	(hh:mm)	(hh:mm)	(hh:mm)	(hh:mm)	(hh:mm)	(hh:mm)	(hh:mm)	(hh:mm)
Fort Collins	5:16	5:31	5:46	6:08		6:53	7:01	7:16	7:46	7:53		8:46			10:01		
North Front Range	5:22	5:37	5:52	6:14		6:59	7:07	7:22	7:52	7:59		8:52			10:07		
North Suburban	5:42	5:57	6:12	6:34		7:19	7:27	7:42	8:12	8:19		9:12			10:27		
DIA													9:39			10:39	
Denver - Union Station	5:59	6:14	6:29	6:51		7:36	7:44	7:59	8:29	8:36		9:29	9:51		10:44	10:51	
<b>US-6 JUNCTION</b>	<b>6:04</b>	<b>6:19</b>	<b>6:34</b>	<b>6:56</b>	<b>7:34</b>	<b>7:41</b>	<b>7:49</b>	<b>8:04</b>	<b>8:34</b>	<b>8:41</b>	<b>9:04</b>	<b>9:34</b>	<b>9:56</b>	<b>10:04</b>	<b>10:49</b>	<b>10:56</b>	<b>11:04</b>
Suburban South				7:04	7:42	7:49				8:49	9:12		10:04	10:12		11:04	11:12
Lone Tree				7:10	7:48	7:55				8:55	9:18		10:10	10:18		11:10	11:18
Castle Rock				7:20	7:58	8:05				9:05	9:28		10:20	10:28		11:20	11:28
Colorado Springs				7:45	8:23	8:30				9:30	9:53		10:45	10:53		11:45	11:53
Colorado Springs South				7:55		8:40				9:40			10:55			11:55	
Pueblo				8:15		9:00				10:00			11:15			12:15	

Train Number	501	608	904	709	503	101	906	610	404	908	612	304	910	614	711	912	505
	(hh:mm)	(hh:mm)	(hh:mm)	(hh:mm)	(hh:mm)	(hh:mm)	(hh:mm)	(hh:mm)	(hh:mm)	(hh:mm)	(hh:mm)	(hh:mm)	(hh:mm)	(hh:mm)	(hh:mm)	(hh:mm)	(hh:mm)
Fort Collins		11:01						12:16	13:01		13:16	14:01		14:16			
North Front Range		11:07						12:22	13:07		13:22	14:07		14:22			
North Suburban		11:27						12:42	13:27		13:42	14:27		14:42			
DIA			11:39				12:39			13:39			14:39			15:39	
Denver - Union Station		11:44	11:51				12:51	12:59	13:44	13:51	13:59	14:44	14:51	14:59		15:51	
<b>US-6 JUNCTION</b>	<b>11:34</b>	<b>11:49</b>	<b>11:56</b>	<b>12:04</b>	<b>12:34</b>	<b>12:49</b>	<b>12:56</b>	<b>13:04</b>	<b>13:49</b>	<b>13:56</b>	<b>14:04</b>	<b>14:49</b>	<b>14:56</b>	<b>15:04</b>	<b>15:49</b>	<b>15:56</b>	<b>16:04</b>
Suburban South	11:42		12:04	12:12	12:42	12:57	13:04			14:04			15:04		15:57	16:04	16:12
Lone Tree	11:48		12:10	12:18	12:48	13:03	13:10			14:10			15:10		16:03	16:10	16:18
Castle Rock	11:58		12:20	12:28	12:58	13:13	13:20			14:20			15:20		16:13	16:20	16:28
Colorado Springs	12:23		12:45	12:53	13:23	13:38	13:45			14:45			15:45		16:38	16:45	16:53
Colorado Springs South			12:55			13:48	13:55			14:55			15:55			16:55	
Pueblo			13:15			14:08	14:15			15:15			16:15			17:15	

Train Number	103	616	914	713	406	916	306	715	806	507	918	408	808	105	509	107	717
	(hh:mm)	(hh:mm)	(hh:mm)	(hh:mm)	(hh:mm)	(hh:mm)	(hh:mm)	(hh:mm)	(hh:mm)	(hh:mm)	(hh:mm)	(hh:mm)	(hh:mm)	(hh:mm)	(hh:mm)	(hh:mm)	(hh:mm)
Fort Collins		16:01			16:31		17:31		18:08			18:31	18:53				
North Front Range		16:07			16:37		17:37		18:14			18:37	18:59				
North Suburban		16:27			16:57		17:57		18:34			18:57	19:19				
DIA			16:39			17:39					18:54						
Denver - Union Station		16:44	16:51		17:14	17:51	18:14		18:51		19:06	19:14	19:36				
<i>US-6 JUNCTION</i>	16:19	16:49	16:56	17:04	17:19	17:56	18:19	18:49	18:56	19:04	19:11	19:19	19:41	20:04	21:19	21:34	21:49
Suburban South	16:27		17:04	17:12		18:04		18:57	19:04	19:12	19:19		19:49	20:12	21:27	21:42	21:57
Lone Tree	16:33		17:10	17:18		18:10		19:03	19:10	19:18	19:25		19:55	20:18	21:33	21:48	22:03
Castle Rock	16:43		17:20	17:28		18:20		19:13	19:20	19:28	19:35		20:05	20:28	21:43	21:58	22:13
Colorado Springs	17:08		17:45	17:53		18:45		19:38	19:45	19:53	20:00		20:30	20:53	22:08	22:23	22:38
Colorado Springs South	17:18		17:55			18:55			19:55		20:10		20:40	21:03		22:33	
Pueblo	17:38		18:15			19:15			20:15		20:30		21:00	21:23		22:53	



**L.5 Pueblo to Fort Collins**

Train Number	100	901	500	801	601	903	700	803	502	905	702	805	102	907	401	301	704
	(hh:mm)	(hh:mm)	(hh:mm)	(hh:mm)	(hh:mm)	(hh:mm)	(hh:mm)	(hh:mm)	(hh:mm)	(hh:mm)	(hh:mm)	(hh:mm)	(hh:mm)	(hh:mm)	(hh:mm)	(hh:mm)	(hh:mm)
Pueblo	4:51	4:59		5:44		5:59		6:29		6:59		7:29	7:36	7:59			
Colorado Springs South	5:11	5:19		6:04		6:19		6:49		7:19		7:49	7:56	8:19			
Colorado Springs	5:21	5:29	5:36	6:14		6:29	6:51	6:59	7:06	7:29	7:51	7:59	8:06	8:29			9:21
Castle Rock	5:46	5:54	6:01	6:39		6:54	7:16	7:24	7:31	7:54	8:16	8:24	8:31	8:54			9:46
Lone Tree	5:56	6:04	6:11	6:49		7:04	7:26	7:34	7:41	8:04	8:26	8:34	8:41	9:04			9:56
Suburban South	6:02	6:10	6:17	6:55		7:10	7:32	7:40	7:47	8:10	8:32	8:40	8:47	9:10			10:02
<i>US-6 JUNCTION</i>	<b>6:11</b>	<b>6:19</b>	<b>6:26</b>	<b>7:04</b>	<b>7:11</b>	<b>7:19</b>	<b>7:41</b>	<b>7:49</b>	<b>7:56</b>	<b>8:19</b>	<b>8:41</b>	<b>8:49</b>	<b>8:56</b>	<b>9:19</b>	<b>9:26</b>	<b>9:41</b>	<b>10:11</b>
Denver - Union Station		6:23		7:08	7:15	7:23		7:53		8:23		8:53		9:23	9:30	9:45	
DIA		6:35				7:35				8:35				9:35			
North Suburban				7:25	7:32			8:10				9:10			9:47	10:02	
North Front Range				7:45	7:52			8:30				9:30			10:07	10:22	
Fort Collins				7:51	7:58			8:36				9:36			10:13	10:28	

Train Number	909	403	706	911	708	913	303	710	915	504	405	917	712	603	919	714	305
	(hh:mm)	(hh:mm)	(hh:mm)	(hh:mm)	(hh:mm)	(hh:mm)	(hh:mm)	(hh:mm)	(hh:mm)	(hh:mm)	(hh:mm)	(hh:mm)	(hh:mm)	(hh:mm)	(hh:mm)	(hh:mm)	(hh:mm)
Pueblo	8:59			9:59		10:59			11:59			12:59			13:59		
Colorado Springs South	9:19			10:19		11:19			12:19			13:19			14:19		
Colorado Springs	9:29		10:21	10:29	11:21	11:29		12:21	12:29	12:36		13:29	13:36		14:29	14:36	
Castle Rock	9:54		10:46	10:54	11:46	11:54		12:46	12:54	13:01		13:54	14:01		14:54	15:01	
Lone Tree	10:04		10:56	11:04	11:56	12:04		12:56	13:04	13:11		14:04	14:11		15:04	15:11	
Suburban South	10:10		11:02	11:10	12:02	12:10		13:02	13:10	13:17		14:10	14:17		15:10	15:17	
<i>US-6 JUNCTION</i>	<b>10:19</b>	<b>10:26</b>	<b>11:11</b>	<b>11:19</b>	<b>12:11</b>	<b>12:19</b>	<b>12:26</b>	<b>13:11</b>	<b>13:19</b>	<b>13:26</b>	<b>14:11</b>	<b>14:19</b>	<b>14:26</b>	<b>15:11</b>	<b>15:19</b>	<b>15:26</b>	<b>16:11</b>
Denver - Union Station	10:23	10:30		11:23		12:23	12:30		13:23		14:15	14:23		15:15	15:23		16:15
DIA	10:35			11:35		12:35			13:35			14:35			15:35		
North Suburban		10:47					12:47				14:32			15:32			16:32
North Front Range		11:07					13:07				14:52			15:52			16:52
Fort Collins		11:13					13:13				14:58			15:58			16:58

Train Number	104	605	716	607	506	807	407	809	106	609	508	307	409	611	613	615	617
	(hh:mm)	(hh:mm)	(hh:mm)	(hh:mm)	(hh:mm)	(hh:mm)	(hh:mm)	(hh:mm)	(hh:mm)	(hh:mm)	(hh:mm)	(hh:mm)	(hh:mm)	(hh:mm)	(hh:mm)	(hh:mm)	(hh:mm)
Pueblo	15:06					17:44		18:29	18:36								
Colorado Springs South	15:26					18:04		18:49	18:56								
Colorado Springs	15:36		16:36		17:36	18:14		18:59	19:06		19:36						
Castle Rock	16:01		17:01		18:01	18:39		19:24	19:31		20:01						
Lone Tree	16:11		17:11		18:11	18:49		19:34	19:41		20:11						
Suburban South	16:17		17:17		18:17	18:55		19:40	19:47		20:17						
<i>US-6 JUNCTION</i>	16:26	17:11	17:26	18:11	18:26	19:04	19:26	19:49	19:56	20:11	20:26	20:56	21:11	21:26	21:41	21:56	22:11
Denver - Union Station		17:15		18:15		19:08	19:30	19:53		20:15		21:00	21:15	21:30	21:45	22:00	22:15
DIA																	
North Suburban		17:32		18:32		19:25	19:47	20:10		20:32		21:17	21:32	21:47	22:02	22:17	22:32
North Front Range		17:52		18:52		19:45	20:07	20:30		20:52		21:37	21:52	22:07	22:22	22:37	22:52
Fort Collins		17:58		18:58		19:51	20:13	20:36		20:58		21:43	21:58	22:13	22:28	22:43	22:58